

- > SEPARATOR COMPACT
- > **SEPARATOR S655**
- > **SEPARATOR S855**
- > SEPARATOR S855 GB
- > PLUG & PLAY



FOR A GREEN WORLD



EN



WASTE WATER TREATMENT

SEPARATOR S655 / S855

ECONOMICAL USE OF EXISTING RESOURCES



SEPARATOR S655 / S855

Economical use of existing resources with up-to-date technologies.

- high-precision components
- constantly high throughput
- low wear costs due to long service life
- easy adjustment
- low maintenance



BAUER
SEPARATOR
S655



BAUER
SEPARATOR
S855

Customary slurry treatment – a problem

Farms with high animal concentrations are faced with great problems due to the big amounts of slurry.

This applies particularly to farms with a high stock per unit of area. Existing legal requirements aggravate the situation.

For this reason, slurry must be treated adequately. Customary slurry treatment systems are time-consuming and labor-intensive and require enormous investments, too.

The BAUER SEPARATOR converts slurry into a valuable fertilizer

Fully-automatic separation – that means splitting up slurry into a liquid and a solid fraction – offers great advantages.

The thin slurry remaining can be distributed any time without any sophisticated homogenizing techniques.

The odorless solid fraction is easy to store without any problems.



Liquid fraction re-used for flushing



Solids re-used for bedding



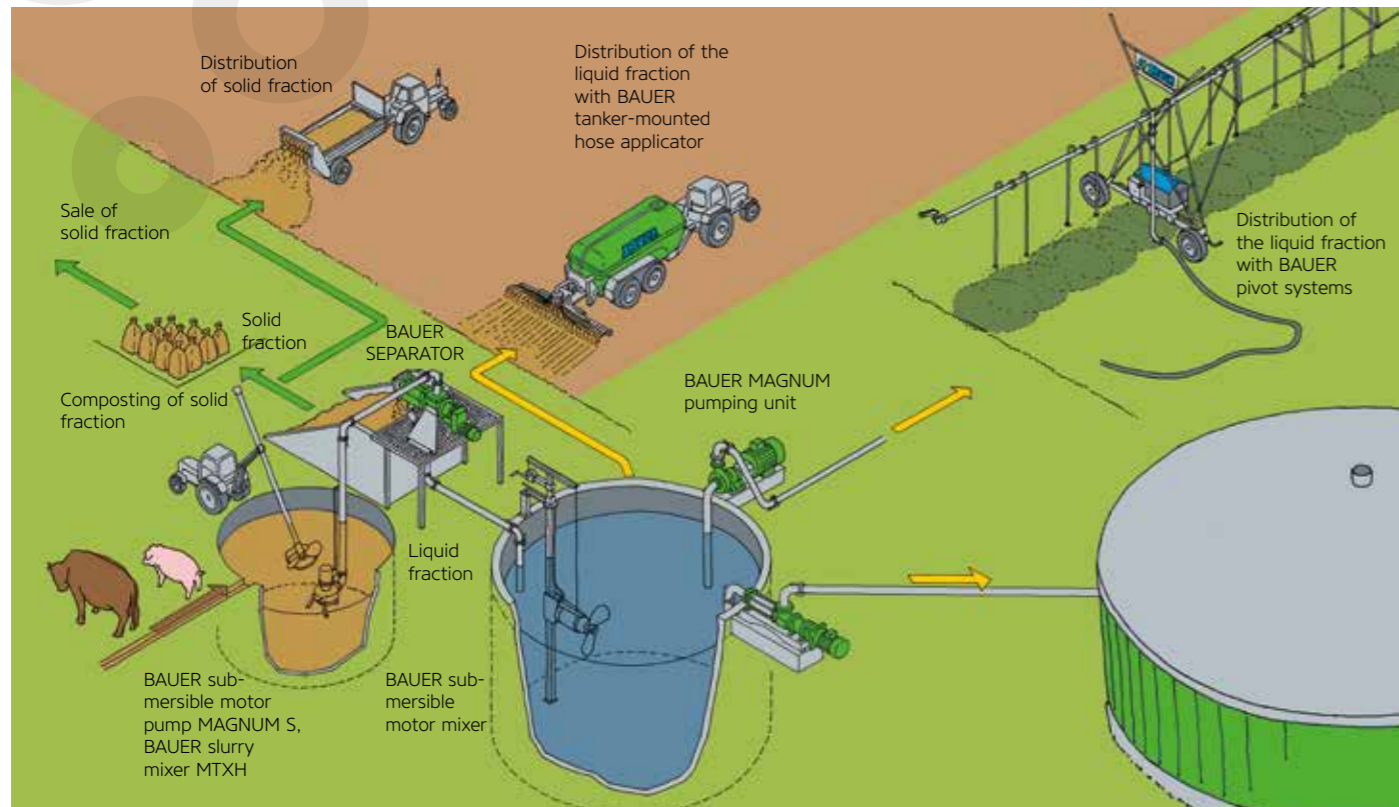

Liquid fraction

- Slurry volume reduced by 15 up to 30%.
- This means less storage space and fewer transports.
- Separated slurry significantly reduces the formation of floating and sinking layers, therefore there is no sophisticated technology necessary to homogenize the slurry before spreading it.
- Lower nitrogen loss (NH_3 , CH_4 , N_2O) during storage and distribution due to extraction of solids and carbon.
- Distinctly reduced smell.
- More accurate nutrient analysis makes it possible to determine the ideal time of distribution.
- Lower nutrient concentration allows a higher application per hectare compared with raw slurry.
- Much better infiltration to the soil and less adhesion to the plants ensure that nutrients are more quickly absorbed and crop damage by burning is minimized.
- Longer distribution period, because overhead application is possible.
- Simple, cost-effective distributing systems.
- Lower energy requirement for pumping and delivery.
- Distinctly reduced weed seed content (especially dock) in the liquid fraction.

Solid fraction

- Self-composting, odor-less and stackable.
- High solids contents allows storage without any special provisions.
- Improves the soil structure and increases the humus content.
- 30% or higher dry matter content allows composting in the open.
- Apart from agricultural areas, suitable also for other applications, where nutrients are required.
- Easy to transport and sell.
- Re-use for bedding.



Dry matter setting

With the setting of the weights you can determine the desired dry matter content (up to 35%) of the solid fraction, if the slurry consistency varies.

←

Separation of raw slurry (= 100%)

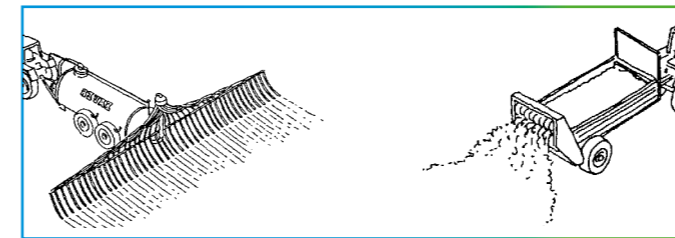

Liquid fraction 70 – 85%

Thin, ideal for delivery through pipe and hose systems

Solid fraction 15 – 30%

odorless, easy to store, can be sold as fertilizer or compost

Screen sizes

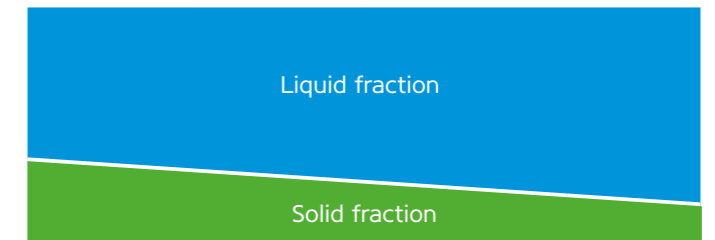

0,35 0,5 0,75 1,0

Four different screen sizes are available for the SEPARATOR. The separation degree also depends on the screen size.

Nutrient distribution by separation

Total raw pig slurry (= 100%)

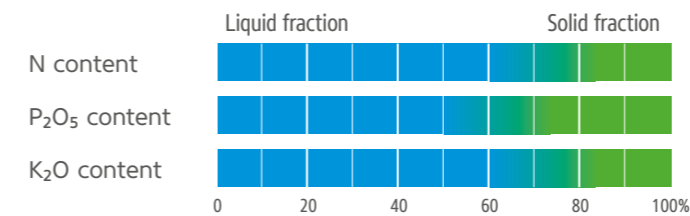

Total raw cattle slurry (= 100%)

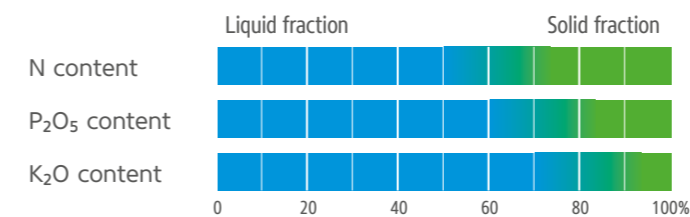

The nutrient-separating capacity varies according to the dry matter content of the raw slurry and the dry matter content of the solid fraction.

Dimensions

S655

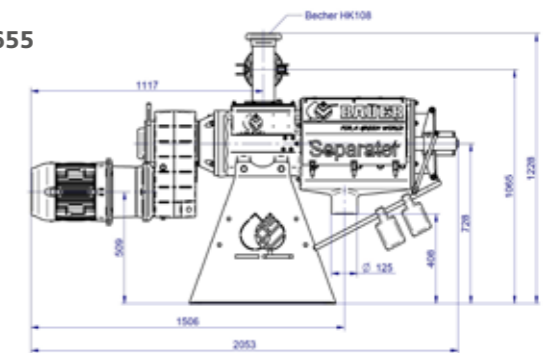

S855

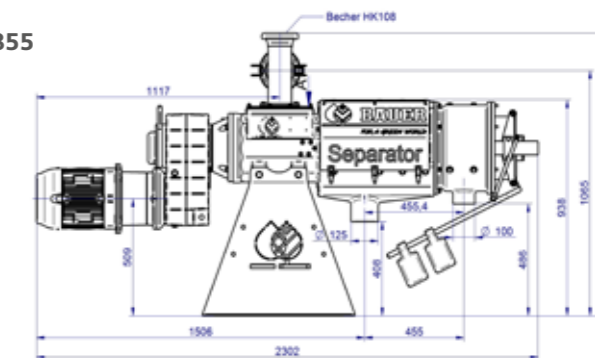



High economic efficiency

Slurry separation is the ideal solution for farms with a large animal population and small distribution areas. It reduces the storage capacity requirement up to 30%.

Through specific use of nutrients of the liquid and solid fractions, mineral fertilizers can be saved. Extra profits are possible by selling the solids for instance to small gardeners or as a basis of compost for horticultural farms.



Large lateral openings

for checking and cleaning of screen.



Strong output

Throughput capacity of raw slurry

Modell	S 655	S 855
Cattle slurry up to m ³ /h	20	30
pPig slurry up to m ³ /h	25	35
Poultry slurry up to m ³ /h	10	15

Throughput depends on age, dry matter content, and viscosity of the raw slurry.

The BAUER SEPARATOR sets new standards also for industrial applications.



Due to its high quality material, top workmanship, and enormous performance capacity, the BAUER SEPARATOR finds nearly unlimited possibilities of application also in the industrial field.

For example:

- **Food industry**
Separation of vegetable waste
- **Slaughter houses**
Separation of paunch content
- **Pharmaceutical industry**
Separation of poppy seed mush
- **Biogas plants**
Before and after fermentation
- **Distilleries**

The advantages

- Waste volume reduced considerably
- Liquid fraction suitable for sewer
- Minimum odor
- Re-use of solid fraction as animal feed or fertilizer

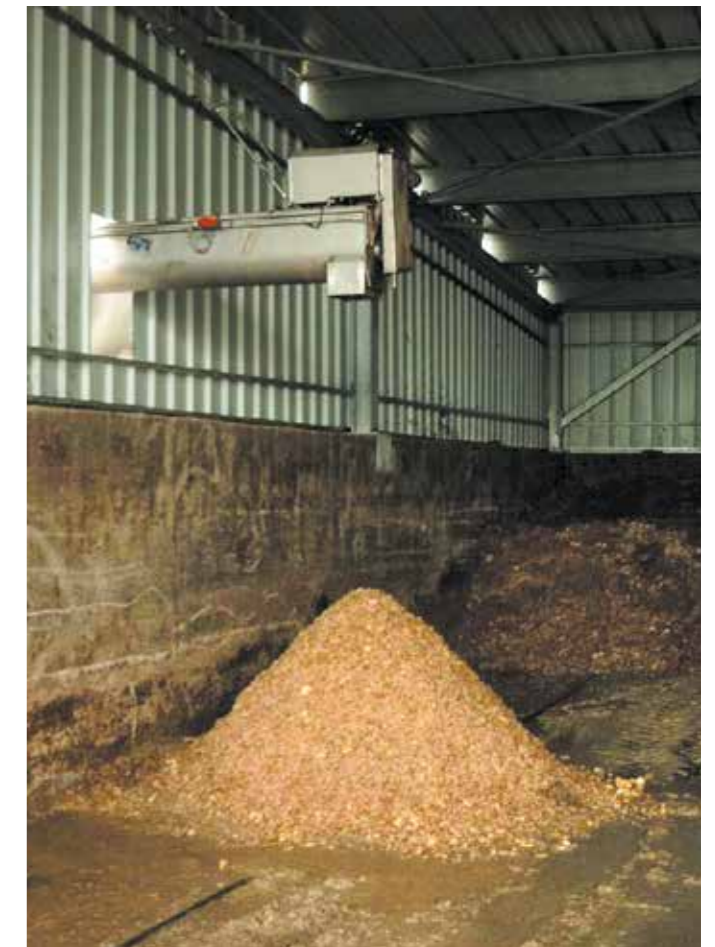

PRODUCTS FROM OUR SLURRY PROGRAM



MTXH
Tractor mixer



MSXH
Submersible motor mixer



SEPARATOR
Press screw separator for solid-liquid separation



SEPARATOR PLUG & PLAY
System for portable slurry separation

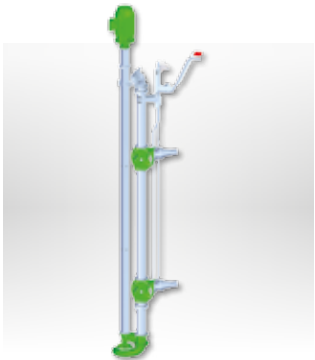

MAGNUM LEE/LEC
Long shaft pump



MAGNUM SM
Thick matter pump gear unit design

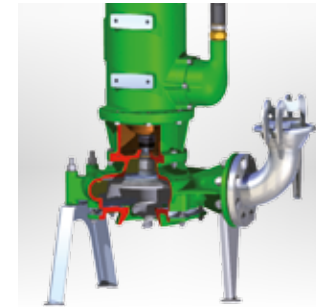

MAGNUM CSPH
Submersible motor pump gear unit design



HELIX DRIVE
Eccentric screw pump



MAGNUM SX
Thick matter pump gear and pedestal pump



Slurry tankers and polyester tanker
Different tanker types for every requirement



Trailing hose applicator
Modular system for all types of tankers



Slurry injector
Innovative spreading technology

Your dealer

 **distrimex**
POMPEN & SERVICE

+31 (0)314 368 444
www.distrimex.nl

