

## Data sheet 50UA2.75-55

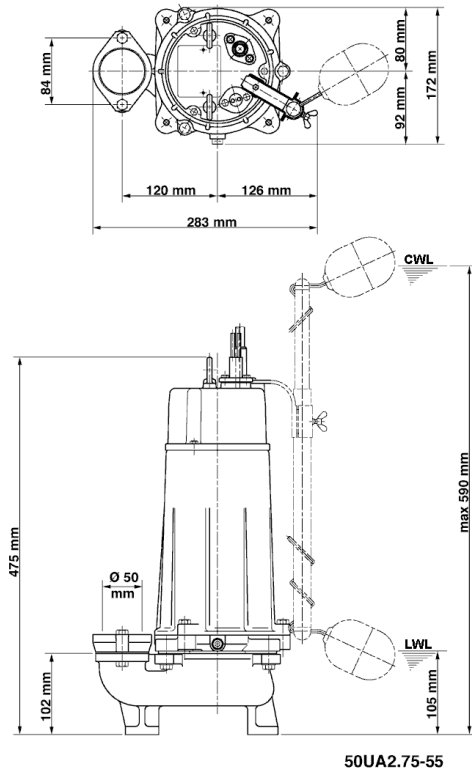

CWL: Continuous running water level  
 LWL: Lowest running water level

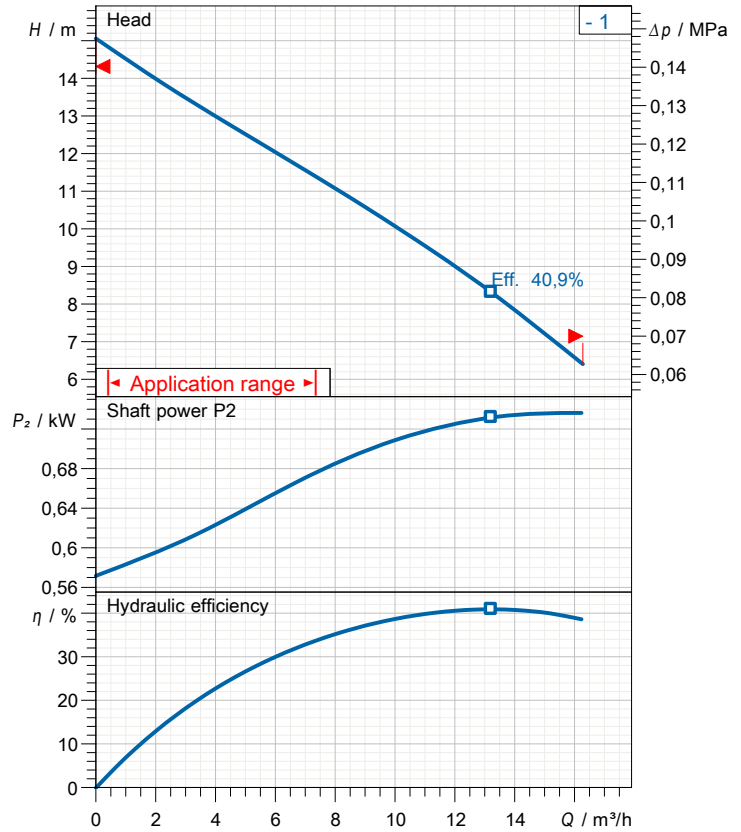

## Specification

Elektrische Tauchpumpe U-Serie  
 Degree of protection IP 68  
 Pressure resistance max. 10 m  
 Type of impeller Vortex impeller  
 Free passage 35 mm  
 Suitable for:  
 waste water and liquid carrying

## Electric motor

Dry-type submersible induction motor  
 Insulation class E 2Poles 2810 1/min  
 Starting mode Direct starting  
 Rated voltage 400 V 50 Hz 3~  
 Power uptake 1,23 kW  
 Rated power 0,75 kW  
 Rated current 2,1 A  
 Start current 8,5 A

## Cable

10m H07RN-F 4Cx1,5mm<sup>2</sup>

## Motor Protection

Circle thermal protector  
 (snap-action bi-metal device)

## Shaft seal

Double inside mechanical seal in oil bath  
 additional lubrication by oil lifting device  
 Primary seal  
 Silicon carbide on ceramic  
 Secondary seal  
 Ceramic on carbon

## Bearings

Shielded ball bearings, maintenance-free

## Materials

Impeller	FC200 (EN-GJL-200)
Pump casing	FC200 (EN-GJL-200)
Motor Frame	FC150 (EN-GJL-150)
Shaft	SUS403 (EN-X6Cr13)

## Discharge size

2" (50mm) screwed-in mating flange

## Weight

24 kg (dry weight of the pump only without cable)

# Performance curve

## 50U2.75-55

Discharge port	2"
FördH	15,1 m
Flow	16,3 m³/h
Rated power	0,75 kW
Power input	1,23 kW
Phases	3~
Voltages	400 V
Frequency	50 Hz
Rated current	2,1 A
Starting current	8,51 A
Number of poles	2
Speed	2810 1/min
Starting mode	Direct starting
Insulation class	E

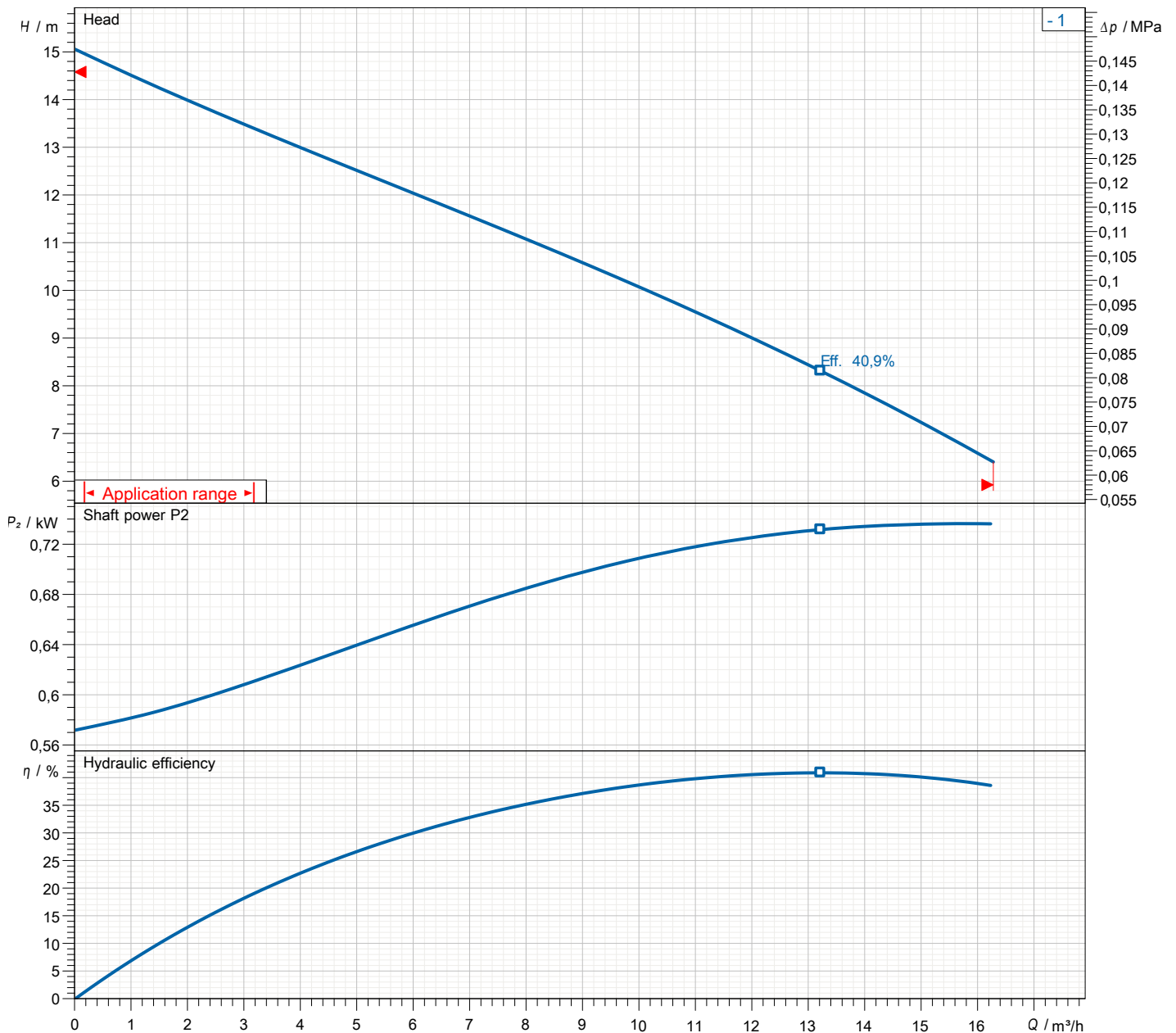

# Dimensions

## 50UA2.75-55

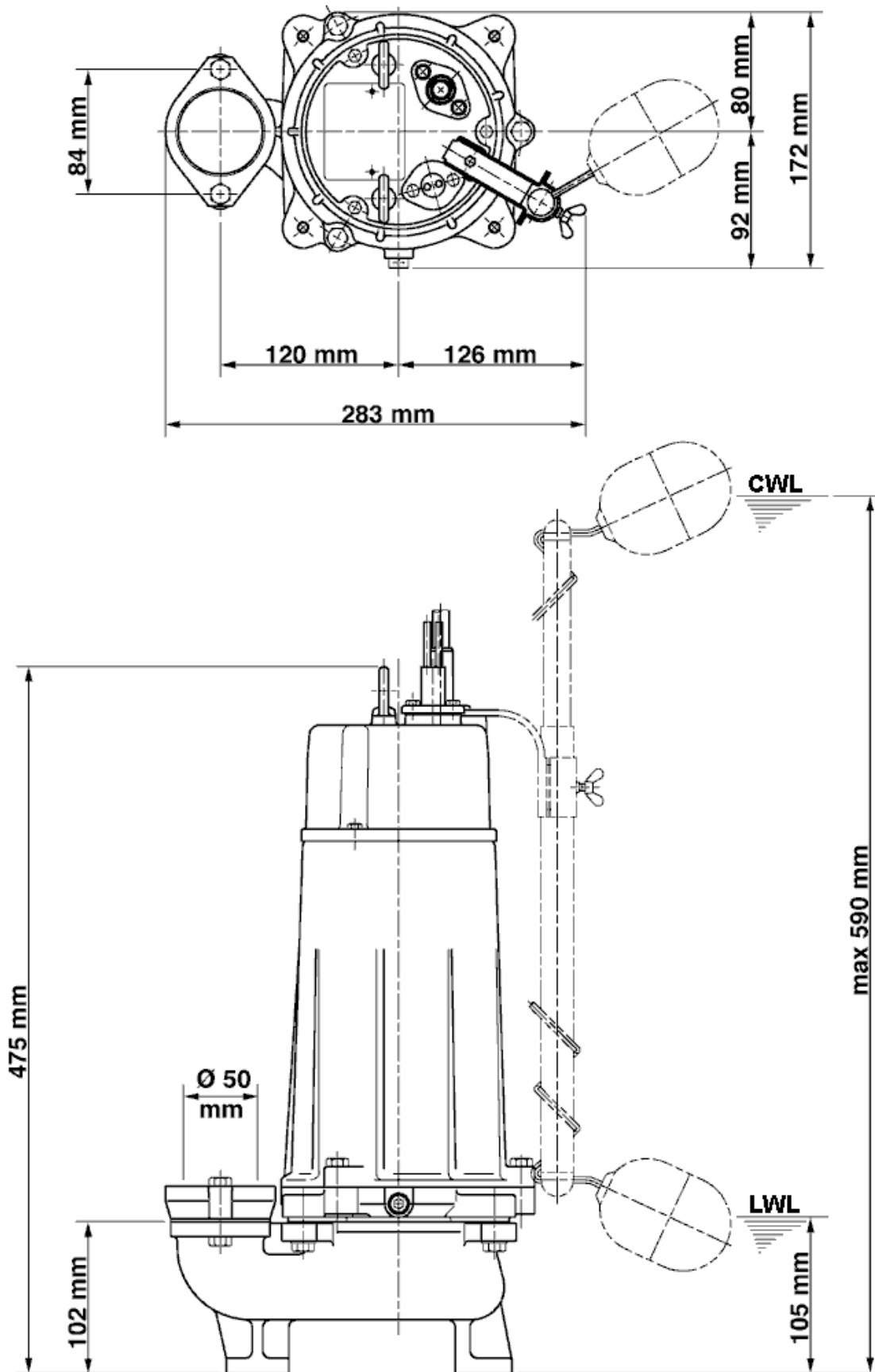

**50UA2.75-55**

CWL: Continuous running water level  
LWL: Lowest running water level

# Sectional drawing 50UA2.75-55

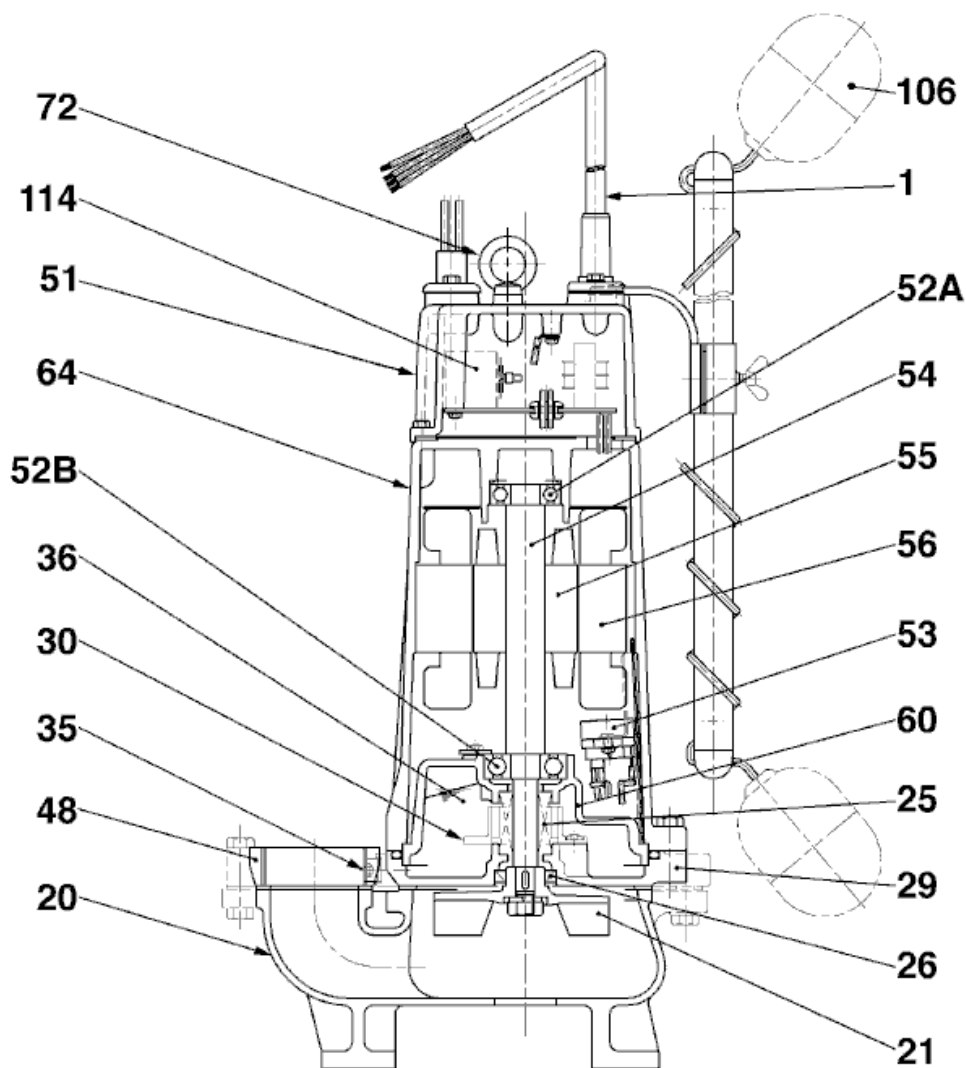

**50UA2.75-55**

No.	Description	Remark	No.	Description	Remark
1	Cable	H07RN-F	60	Bearing Housing	FC150 (EN-GJL-150)
20	Pump casing	FC200 (EN-GJL-200)	64	Motor Frame	FC150 (EN-GJL-150)
21	Impeller	FC200 (EN-GJL-200)	72	Eye screw (2x)	SUS304 (EN-X5CrNi18-10)
25	Mechanical seal	W-14HL	106	Float (2x)	Plastic
26	Oil seal	SC-22357	114	Relais	.
29	Oil casing	FC150 (EN-GJL-150)			
30	Oil distributor	Plastic			
35	Oil screw	SUS304 (EN-X5CrNi18-10)			
36	Lubricant	Turbine oil (ISO VG32)			
48	Screwed Flange	FC200 (EN-GJL-200)			
52A	Upper bearing	6203ZZC3			
52B	Lower Bearing	6303ZZC3			
53	Motor Protector 380/400/415V-50Hz	KA314-HRXL00 (H.C)			
54	Shaft	SUS403 (EN-X6Cr13)			
55	Rotor	.			
56	Stator	.			