

Data sheet KTZ32.2-51

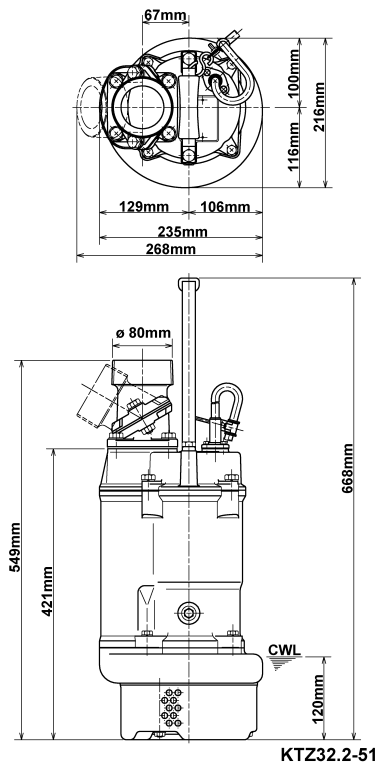

CWL: Continuous running water level

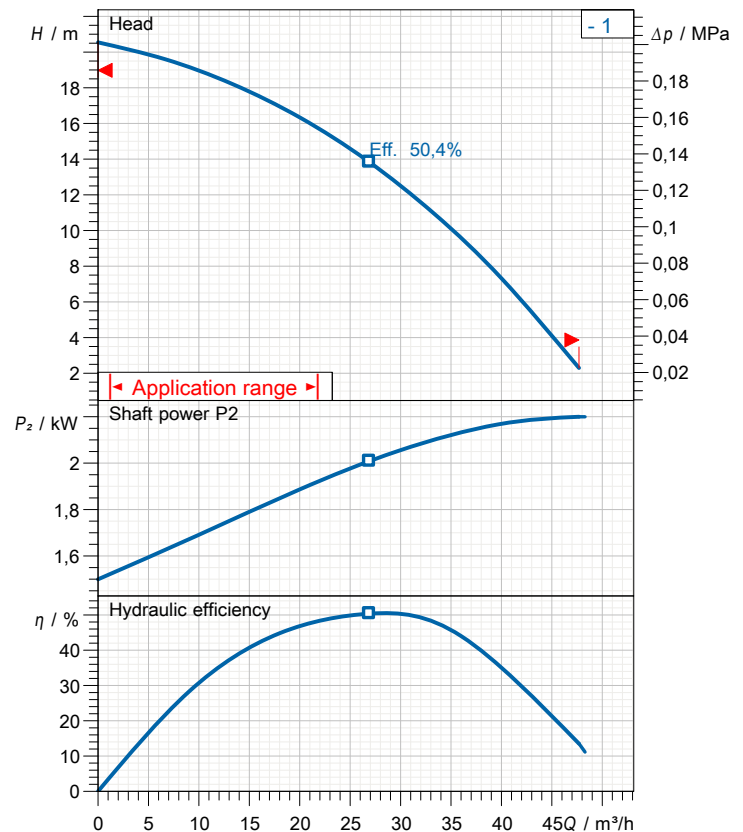

Specification

Elektrische Tauchpumpe KTZ-Serie
 Degree of protection IP 68
 Pressure resistance max. 25 m
 Type of impeller Semi-open
 Max. solid handling 8,5 mm
 Suitable for:
 spring-/rain-/waste-/ground water, water containing sand

Shaft seal

Double inside mechanical seal in oil bath
 additional lubrication by oil lifting device
 Primary seal
 Silicon carbide on silicon carbide
 Secondary seal
 Silicon carbide on silicon carbide

Electric motor

Dry-type submersible induction motor
 Insulation class F 2Poles 2840 1/min
 Starting mode Direct starting
 Rated voltage 400 V 50 Hz 3~
 Power uptake 3,14 kW
 Rated power 2,20 kW
 Rated current 5 A
 Start current 34,0 A

Cable

20m NSSHÖU 4Cx1,5mm²

Motor Protection

Circle thermal protector
 (snap-action bi-metal device)

Bearings

Shielded ball bearings, maintenance-free

Materials

Impeller	Chromium Iron HiCrFC
Pump casing	FC200 (EN-GJL-200)
Suction cover	FCD50 (EN-GJS-500-7)
Motor Frame	FC150 (EN-GJL-150)
Shaft	SUS420J2 (EN-X30Cr13)

Discharge size

3" (80mm) BS-coupling (threaded flange)

Weight

35 kg (dry weight of the pump only without cable)

Performance curve

KTZ32.2-51

Discharge port	3"
FördH	20,5 m
Flow	47,7 m³/h
Rated power	2,20 kW
Power input	3,14 kW
Phases	3~
Voltages	400 V
Frequency	50 Hz
Rated current	5 A
Starting current	34,00 A
Number of poles	2
Speed	2840 1/min
Starting mode	Direct starting
Insulation class	F

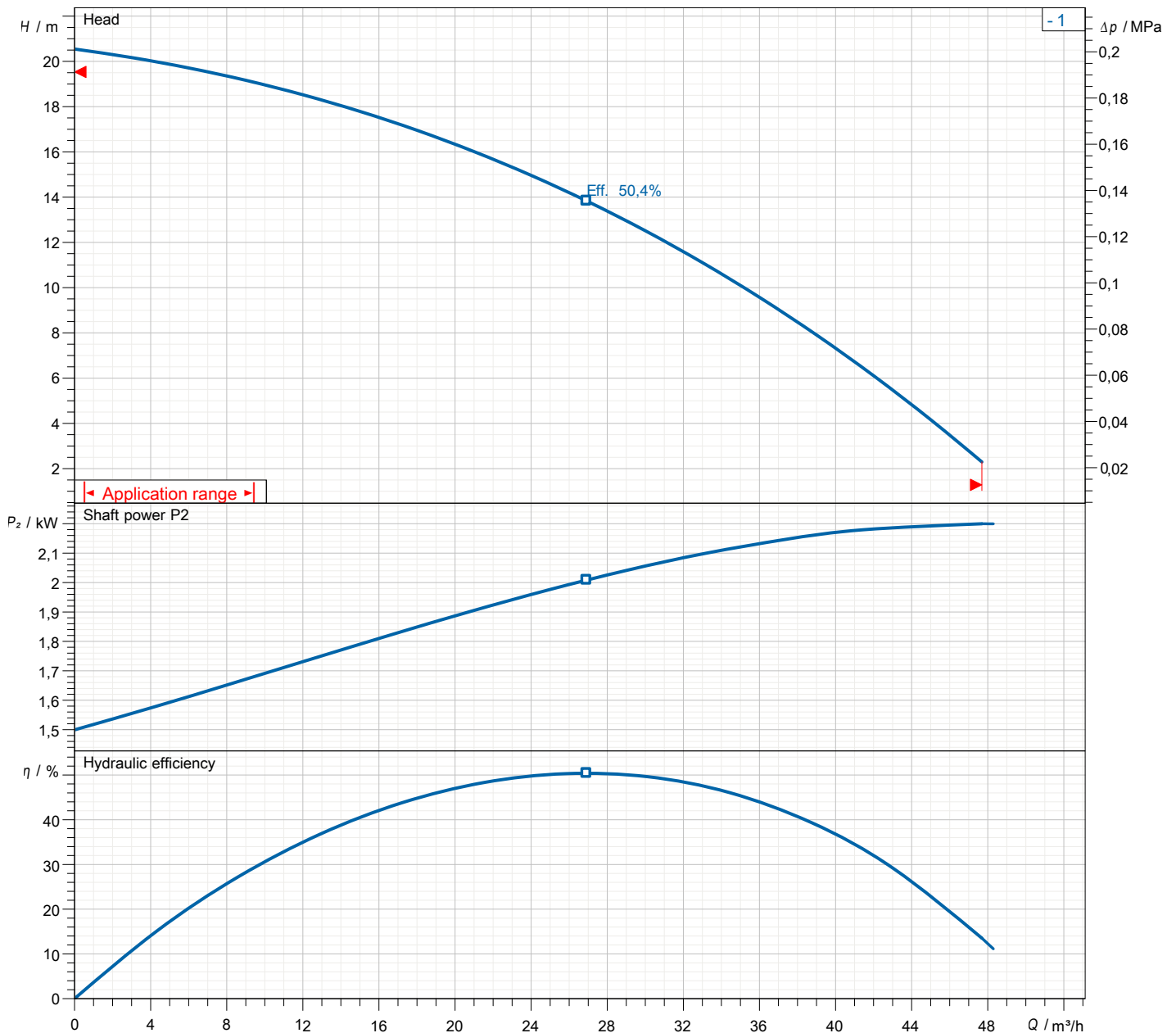

Dimensions KTZ32.2-51

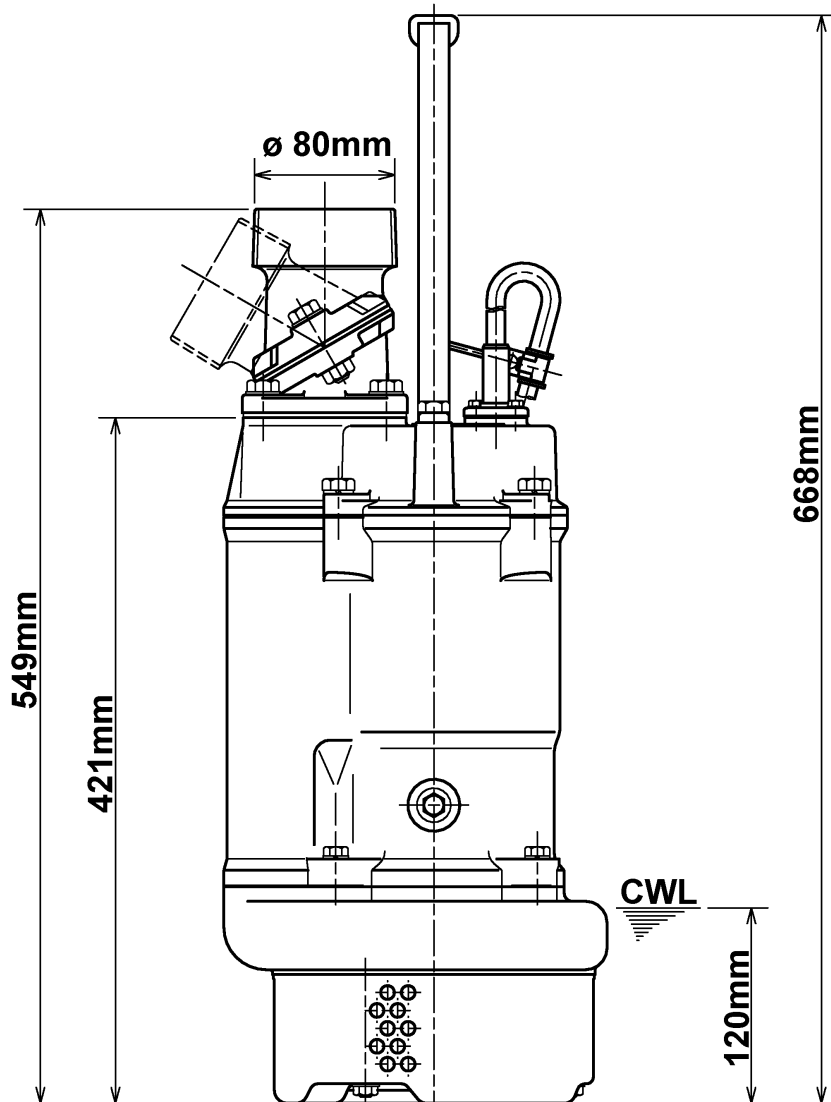
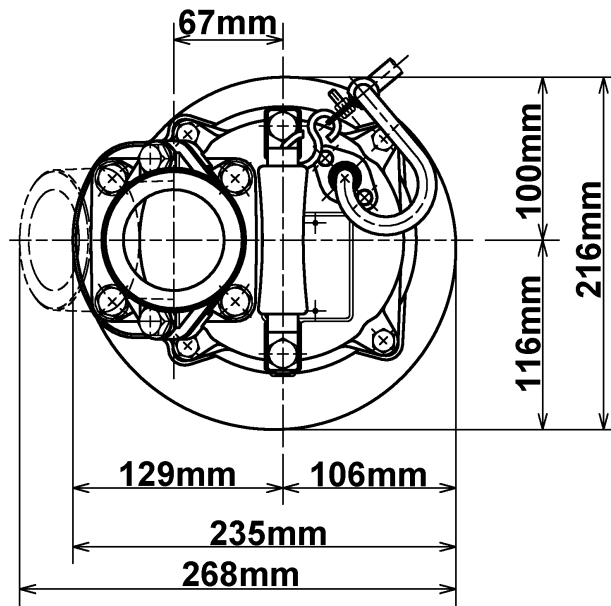

KTZ32.2-51

CWL: Continuous running water level
LWL: Lowest running water level

Sectional drawing KTZ32.2-51

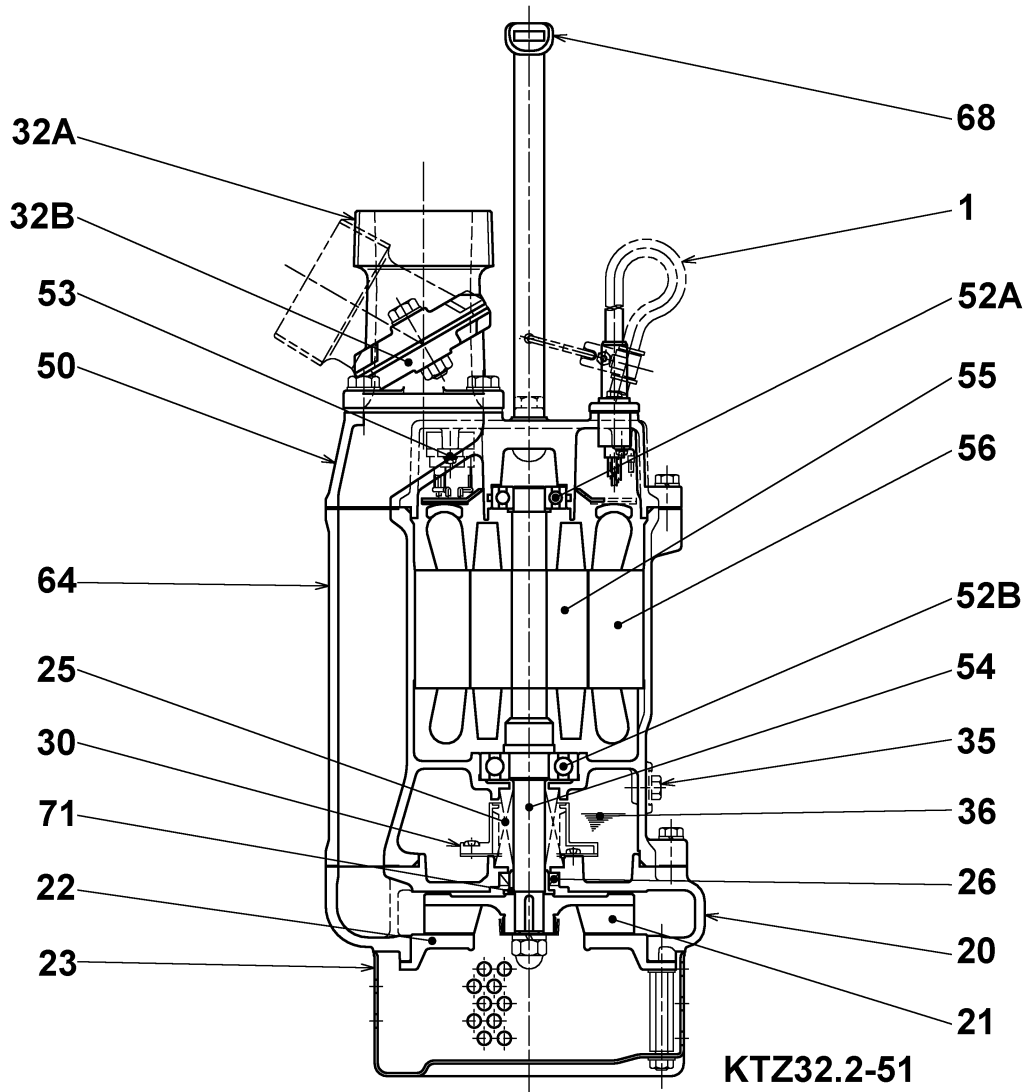

No.	Description	Remark	No.	Description	Remark
1	Cable	20m NSSHÖU	55	Rotor	.
20	Pump casing	FC200 (EN-GJL-200)	56	Stator	.
21	Impeller	Chromium Iron HiCrFC	64	Motor Frame	FC150 (EN-GJL-150)
22	Suction cover	FCD50 (EN-GJS-500-7)	68	Handle	Steelplate and rubber
23	Strainer	Steel plate	71	Shaft protection sleeve	SUS304 (EN-X5CrNi18-10)
25	Mechanical seal	H-20T			
26	Oil seal	TC25388			
30	Oil distributor	Plastic			
32	Discharge coupling	Aluminium die casting			
35	Oil screw	SUS304 (EN-X5CrNi18-10)			
36	Lubricant	Turbine oil (ISO VG32)			
50	Main cover	FC150 (EN-GJL-150)			
52A	Upper bearing	6204ZZC3			
52B	Lower bearing	6305ZZC3			
53	Motor Protector 380/400/415V-50Hz	KA314-HRXL00 (H.C)			
54	Shaft	SUS420J2 (EN-X30Cr13)			